

ZLWF - STANDARD POLYIMIDE JACKET SILICA/SILICA FIBERS		
CORE/CLADDING RATIO 1.07	CORE/CLADDING RATIO 1.1	CORE/CLADDING RATIO 1.2
ZLWF100/107P//120	ZWF50/557P//65-	ZLWF50/60P//70
ZLWF187/200P//220	ZLWF90/100P//107	ZLWF200/240P//265
ZLWF280/300P//325	ZLWF100/110P//125	
ZLWF300/321P//350	ZLWF150/165P//185	
ZLWF400/428P//455	ZLWF200/220P//245	
	ZLWF300/330P//360	
	ZLWF400/440P//470	
	ZLWF600/660P//690	

- NOTES:
1. HERAEUS FLUOSIL® SWU PREFORM.
 2. EXCELLENT TRANSMISSION IN THE RANGE 400-2200 NM.
 3. HIGH POWER LASER TRANSMISSION.
 4. STRESS PROOF LOAD 70KPSI.
 5. OPERATION TEMPERATURE FROM -190°C TO +390°C

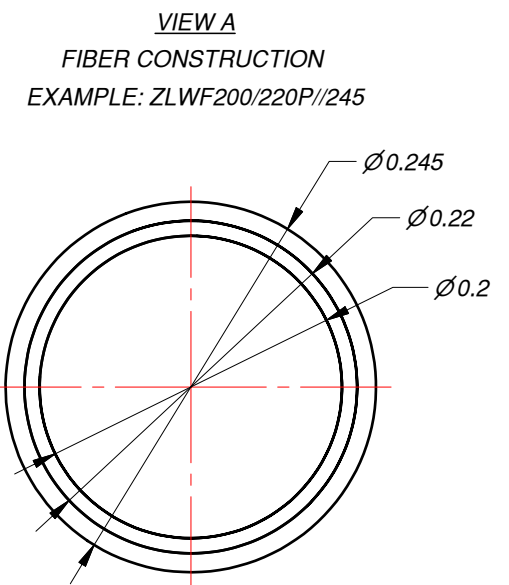

OTHER FIBER DIMENSION AVAILABLE ON REQUEST.
PLEASE CONTACT US FOR DISCUSSIONS.

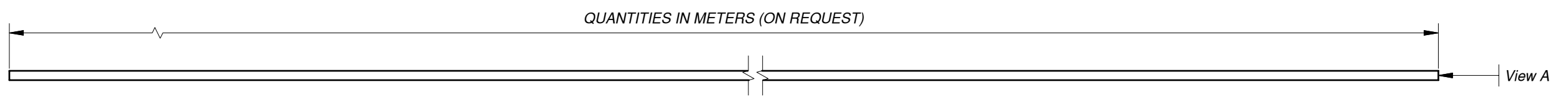

FIBER CODE EXPLANATION

ZLWF **200** / **220** P// **245** -

PURE FUSED SILICA CORE [MICRONS]	FLUORINE DOPED FUSED SILICA CLADDING [MICRONS]	POLYIMIDE JACKET [MICRONS]	NUMERICAL APERATURE [NA]
			STANDARD, NA=0.22±0.02
			0.26 HIGH NA, NA=0.26±0.02
			LNA LOW NA, ON REQUEST

OTHER FIBER DIMENSION AVAILABLE ON REQUEST.
PLEASE CONTACT US FOR DISCUSSIONS.

TYPICAL FIBER ATTENUATION

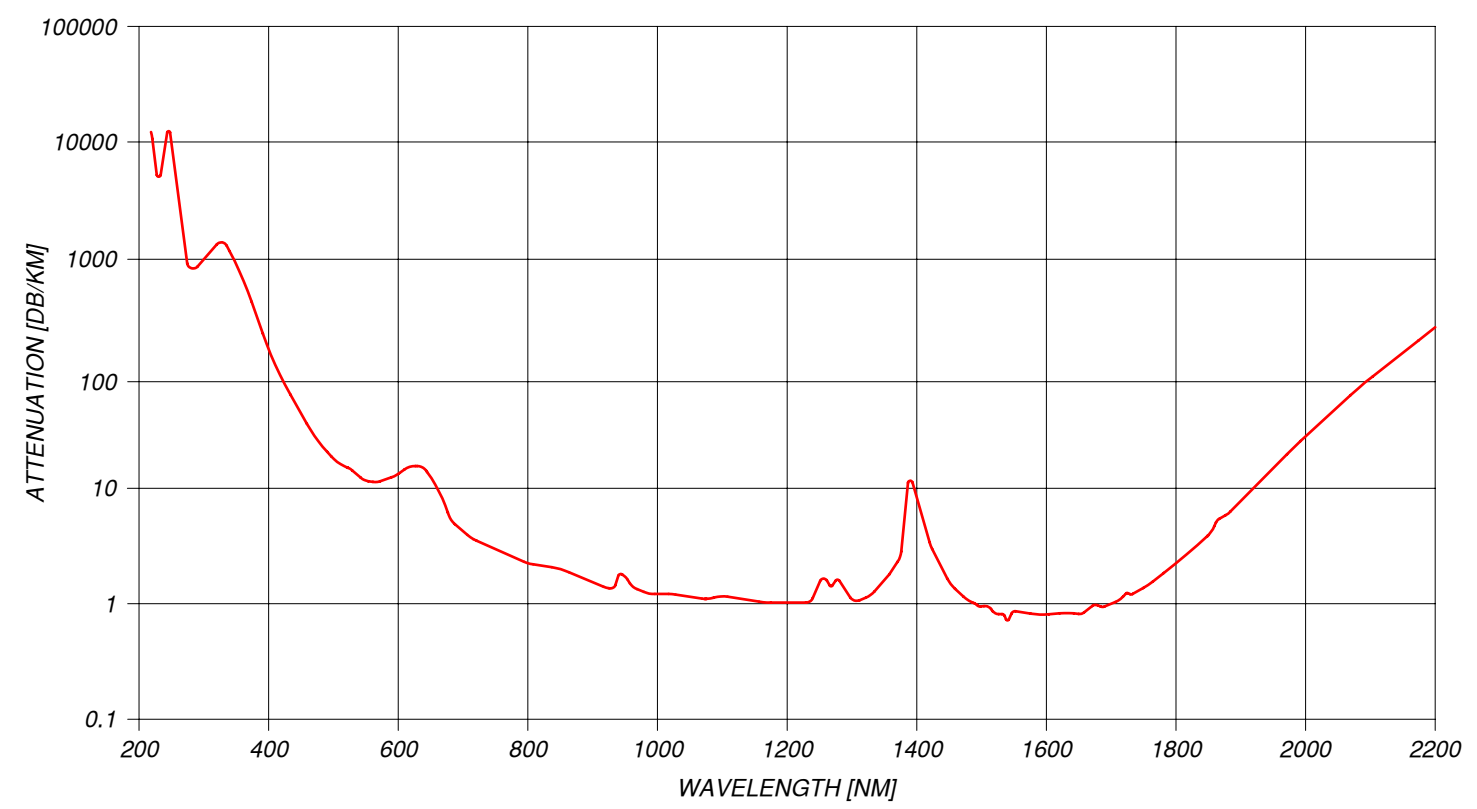

TITLE: ZLWF - POLYIMIDE JACKET SILICA/SILICA FIBERS		
SIZE: A3	DRAWING NO.: ZLWF-001-00	REV.: A
FILE NAME: ZLWF-POLYIMIDE.idw	ITEM NO.:	
COMPANY: Z-LIGHT, LTD.	CODE NO.:	
HOME PAGE: HTTP://WWW.Z-LIGHT.LV	ORDER NO.:	
SCALE: DO NOT SCALE	DIMENSIONS ARE IN MM	SHEET 1 OF 1